

Property Record Card



Parcel: **22-21-29-507-0G00-0100**
 Property Address: **185 LAKE DESTINY TRL ALTAMONTE SPRINGS, FL 32714**
 Owners: **HAMBLY, BRENT C; HAMBLY, JENNIFER S**
 2026 Market Value \$704,580 Assessed Value \$704,580 Taxable Value \$704,580
 2025 Tax Bill \$9,315.33
 The 4 Bed/5 Bath Single Family property is 3,876 SF and a lot size of 0.47 Acres

Parcel Location



Site View



2221295070G000100 02/21/2024

Parcel Information

Parcel	22-21-29-507-0G00-0100
Property Address	185 LAKE DESTINY TRL ALTAMONTE SPRINGS, FL 32714
Mailing Address	185 LAKE DESTINY TRL ALTAMONTE SPG, FL 32714-3458
Subdivision	SPRING LAKE HILLS SEC 3
Tax District	01:County Tax District
DOR Use Code	01:Single Family
Exemptions	None
AG Classification	No

Value Summary

	2026 Working Values	2025 Certified Values
Valuation Method	Cost/Market	Cost/Market
Number of Buildings	1	1
Depreciated Building Value	\$533,738	\$538,434
Depreciated Other Features	\$30,842	\$27,561
Land Value (Market)	\$140,000	\$115,000
Land Value Agriculture	\$0	\$0
Just/Market Value	\$704,580	\$680,995
Portability Adjustment	\$0	\$0
Save Our Homes Adjustment/Maximum Portability	\$0	\$0
Non-Hx 10% Cap (AMD 1)	\$0	\$0
P&G Adjustment	\$0	\$0
Assessed Value	\$704,580	\$680,995

2025 Certified Tax Summary

Tax Amount w/o Exemptions	\$9,315.33
Tax Bill Amount	\$9,315.33
Tax Savings with Exemptions	\$0.00

Note: Does NOT INCLUDE Non Ad Valorem Assessments

Owner(s)

Name - Ownership Type

HAMBLY, BRENT C - Tenancy by Entirety
 HAMBLY, JENNIFER S - Tenancy by Entirety

Legal Description

LOT 10 (LESS NLY 5 FT)
BLK G
SPRING LAKE HILLS SEC 3
PB 16 PG 48

Taxes

Taxing Authority	Assessed	Exempt Amount	Taxable
COUNTY GENERAL FUND	\$704,580	\$0	\$704,580
Schools	\$704,580	\$0	\$704,580
FIRE	\$704,580	\$0	\$704,580
ROAD DISTRICT	\$704,580	\$0	\$704,580
SJWM(Saint Johns Water Management)	\$704,580	\$0	\$704,580

Sales

Deed Type	Date	Sale Amount	Book / Page	Sale Type	Qualified?
WARRANTY DEED	5/12/2023	\$879,000	10438/0512	Improved	Yes
WARRANTY DEED	6/1/2016	\$420,000	08706/1171	Improved	Yes
WARRANTY DEED	5/1/2010	\$350,000	07383/1273	Improved	Yes
WARRANTY DEED	2/1/1996	\$150,000	03038/1893	Improved	Yes
WARRANTY DEED	7/1/1979	\$99,900	01235/0166	Improved	Yes
WARRANTY DEED	2/1/1978	\$71,000	01158/0343	Improved	Yes

Land

Units	Rate	Assessed	Market
1 Lot	\$140,000/Lot	\$140,000	\$140,000

Building Information	
#	1
Use	SINGLE FAMILY
Year Built*	1972/1992
Bed	4
Bath	5.0
Fixtures	19
Base Area (ft ²)	2129
Total Area (ft ²)	4816
Constuction	CB/STUCCO FINISH
Replacement Cost	\$626,086
Assessed	\$533,738

* Year Built = Actual / Effective

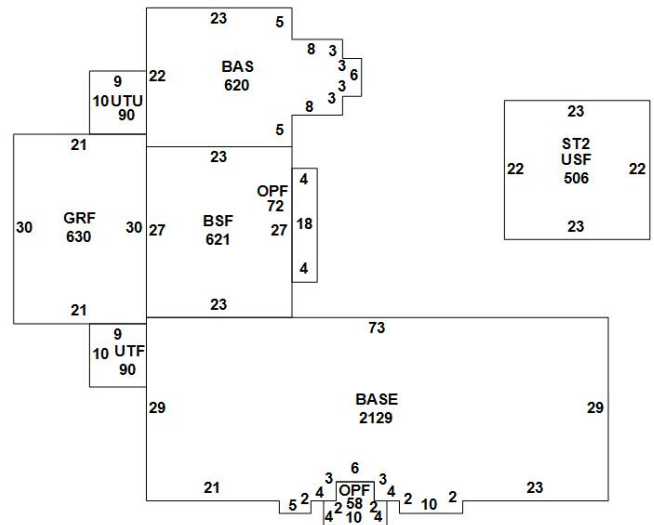

Building 1

Appendages	
Description	Area (ft ²)
BASE	620
BASE SEMI FINISHED	621
GARAGE FINISHED	630
OPEN PORCH FINISHED	72
OPEN PORCH FINISHED	58
UPPER STORY FINISHED	506
UTILITY FINISHED	90
UTILITY UNFINISHED	90

Permits				
Permit #	Description	Value	CO Date	Permit Date
05478	185 LAKE DESTINY TRL: EZ ELECTRICAL - RESIDENTIAL- [SPRING LAKE HILLS SEC 3]	\$4,893		4/12/2024
11837	185 LAKE DESTINY TRL: EZ ELECTRICAL - RESIDENTIAL- [SPRING LAKE HILLS SEC 3]	\$6,977		7/26/2023
06102	185 LAKE DESTINY TRL: REROOF RESIDENTIAL-HOUSE [SPRING LAKE HILLS SEC 3]	\$20,475		4/25/2023
14058	185 LAKE DESTINY TRL: FENCE/WALL RESIDENTIAL- [SPRING LAKE HILLS SEC 3]	\$10,000		1/24/2020
03967	INTERIOR REMODEL	\$22,700		5/18/2010
09266	ADDITION	\$127,794		11/1/1999

Extra Features				
Description	Year Built	Units	Cost	Assessed

POOL 1	1972	1	\$35,000	\$21,000
ELECTRIC HEATER - UNIT	1972	1	\$1,653	\$992
PATIO NO VALUE	1972	1	\$0	\$0
FIREPLACE 1	1972	1	\$3,000	\$1,800
COVERED PATIO 1	1990	1	\$2,750	\$1,650
SCREEN ENCL 2	2000	1	\$9,000	\$5,400

Zoning	
Zoning	R-1AAA
Description	Single Family-13500
Future Land Use	LDR
Description	Low Density Residential

Political Representation	
Commissioner	District 3 - Lee Constantine
US Congress	District 7 - Cory Mills
State House	District 38 - David Smith
State Senate	District 10 - Jason Brodeur
Voting Precinct	Precinct 53

School Districts	
Elementary	Spring Lake
Middle	Milwee
High	Lyman

Utilities	
Fire Station #	Station: 14 Zone: 144
Power Company	DUKE
Phone (Analog)	CENTURY LINK
Water	Altamonte Springs
Sewage	City Of Altamonte Springs
Garbage Pickup	TUE/FRI
Recycle	WED
Yard Waste	WED
Hauler #	Waste Management

Property Value History

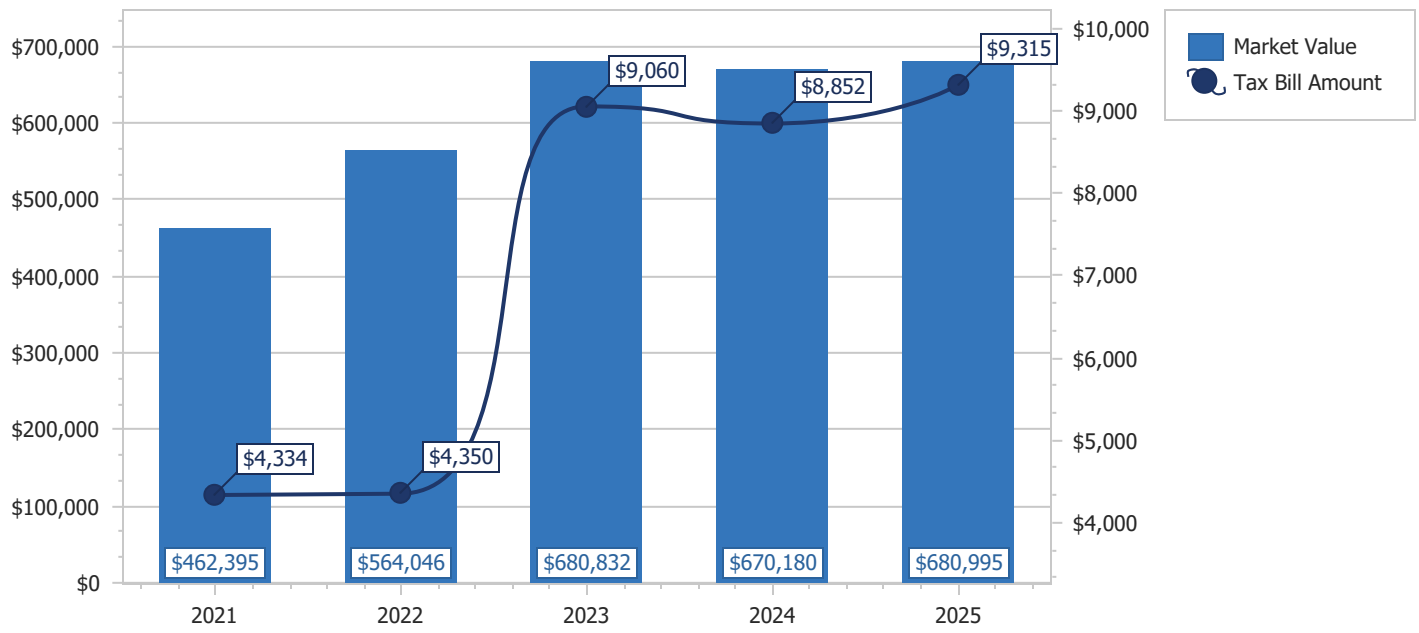

Copyright 2026 © Seminole County Property Appraiser