

Property Record Card



Parcel: **20-21-30-523-0000-0040**
 Property Address: **107 EASTWIND LN FERN PARK, FL 32730**
 Owners: **MARTINEZ, BRENDA LIN C**
 2026 Market Value \$258,017 Assessed Value \$258,017 Taxable Value \$206,606
 2025 Tax Bill \$3,018.60 Tax Savings with Exemptions \$558.81
 The 3 Bed/2.5 Bath Townhome property is 1,904 SF and a lot size of 0.06 Acres

Parcel Location



Site View



Parcel Information

Parcel	20-21-30-523-0000-0040
Property Address	107 EASTWIND LN FERN PARK, FL 32730
Mailing Address	107 EASTWIND LN FERN PARK, FL 32730-4231
Subdivision	LAKE OF THE WOODS SEC 01 TOWNHOUSE
Tax District	01:County Tax District
DOR Use Code	0103:Townhome
Exemptions	00-HOMESTEAD (2023)
AG Classification	No

Value Summary

	2026 Working Values	2025 Certified Values
Valuation Method	Cost/Market	Cost/Market
Number of Buildings	1	1
Depreciated Building Value	\$193,017	\$196,526
Depreciated Other Features	\$0	\$0
Land Value (Market)	\$65,000	\$65,000
Land Value Agriculture	\$0	\$0
Just/Market Value	\$258,017	\$261,526
Portability Adjustment	\$0	\$0
Save Our Homes Adjustment/Maximum Portability	\$0	\$0
Non-Hx 10% Cap (AMD 1)	\$0	\$0
P&G Adjustment	\$0	\$0
Assessed Value	\$258,017	\$261,526

2025 Certified Tax Summary

Tax Amount w/o Exemptions	\$3,577.41
Tax Bill Amount	\$3,018.60
Tax Savings with Exemptions	\$558.81

Owner(s)

Name - Ownership Type
 MARTINEZ, BRENDA LIN C

Note: Does NOT INCLUDE Non Ad Valorem Assessments

Legal Description

LOT 4
LAKE OF THE WOODS
TOWNHOUSE SEC 1
PB 19 PG 50

Taxes

Taxing Authority	Assessed	Exempt Amount	Taxable
COUNTY GENERAL FUND	\$258,017	\$51,411	\$206,606
Schools	\$258,017	\$25,000	\$233,017
FIRE	\$258,017	\$51,411	\$206,606
ROAD DISTRICT	\$258,017	\$51,411	\$206,606
SJWM(Saint Johns Water Management)	\$258,017	\$51,411	\$206,606

Sales

Deed Type	Date	Sale Amount	Book / Page	Sale Type	Qualified?
WARRANTY DEED	9/23/2022	\$307,000	10323/0149	Improved	Yes
WARRANTY DEED	3/1/2015	\$111,000	08444/1093	Improved	No
CORRECTIVE DEED	3/1/2013	\$100	07987/1373	Improved	No
QUIT CLAIM DEED	10/1/2008	\$100	07075/0264	Improved	No
QUIT CLAIM DEED	3/1/2002	\$114,000	04357/0488	Improved	No
WARRANTY DEED	2/1/2002	\$126,900	04339/1937	Improved	Yes
WARRANTY DEED	3/1/1994	\$89,000	02752/0766	Improved	Yes
QUIT CLAIM DEED	9/1/1988	\$100	01999/0629	Improved	No
WARRANTY DEED	9/1/1988	\$73,000	01993/1226	Improved	Yes
WARRANTY DEED	10/1/1987	\$68,000	01902/1486	Improved	No
WARRANTY DEED	2/1/1981	\$69,900	01322/1996	Improved	Yes
WARRANTY DEED	1/1/1977	\$38,900	01123/0782	Improved	Yes

Land

Units	Rate	Assessed	Market
1 Lot	\$65,000/Lot	\$65,000	\$65,000

Building Information	
#	1
Use	SINGLE FAMILY
Year Built*	1974
Bed	3
Bath	2.5
Fixtures	9
Base Area (ft ²)	882
Total Area (ft ²)	2429
Constuction	CB/STUCCO FINISH
Replacement Cost	\$280,752
Assessed	\$193,017

* Year Built = Actual / Effective

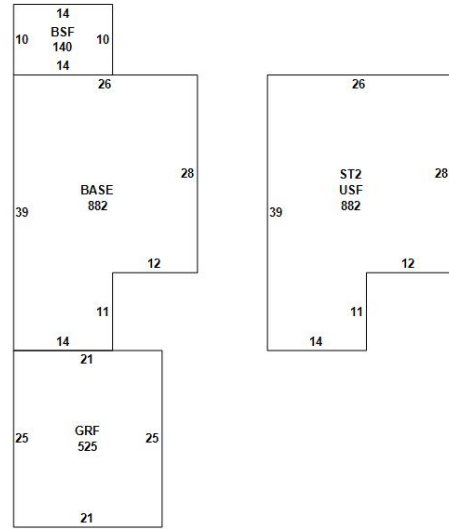

Building 1

Appendages	
Description	Area (ft ²)
BASE SEMI FINISHED	140
GARAGE FINISHED	525
UPPER STORY FINISHED	882

Permits				
Permit #	Description	Value	CO Date	Permit Date
10713	REROOF	\$7,478		9/19/2006

Extra Features				
Description	Year Built	Units	Cost	Assessed

Zoning	
Zoning	R-3A
Description	Multi-Family-10DU
Future Land Use	HDR
Description	High Density Residential

School Districts	
Elementary	English Estates
Middle	South Seminole
High	Lake Howell

Political Representation	
Commissioner	District 4 - Amy Lockhart
US Congress	District 7 - Cory Mills
State House	District 38 - David Smith
State Senate	District 10 - Jason Brodeur
Voting Precinct	Precinct 62

Utilities	
Fire Station #	Station: 22 Zone: 222
Power Company	DUKE
Phone (Analog)	CENTURY LINK
Water	Casselberry
Sewage	City Of Casselberry
Garbage Pickup	TUE/FRI
Recycle	FRI
Yard Waste	WED
Hauler #	Waste Management

Property Value History

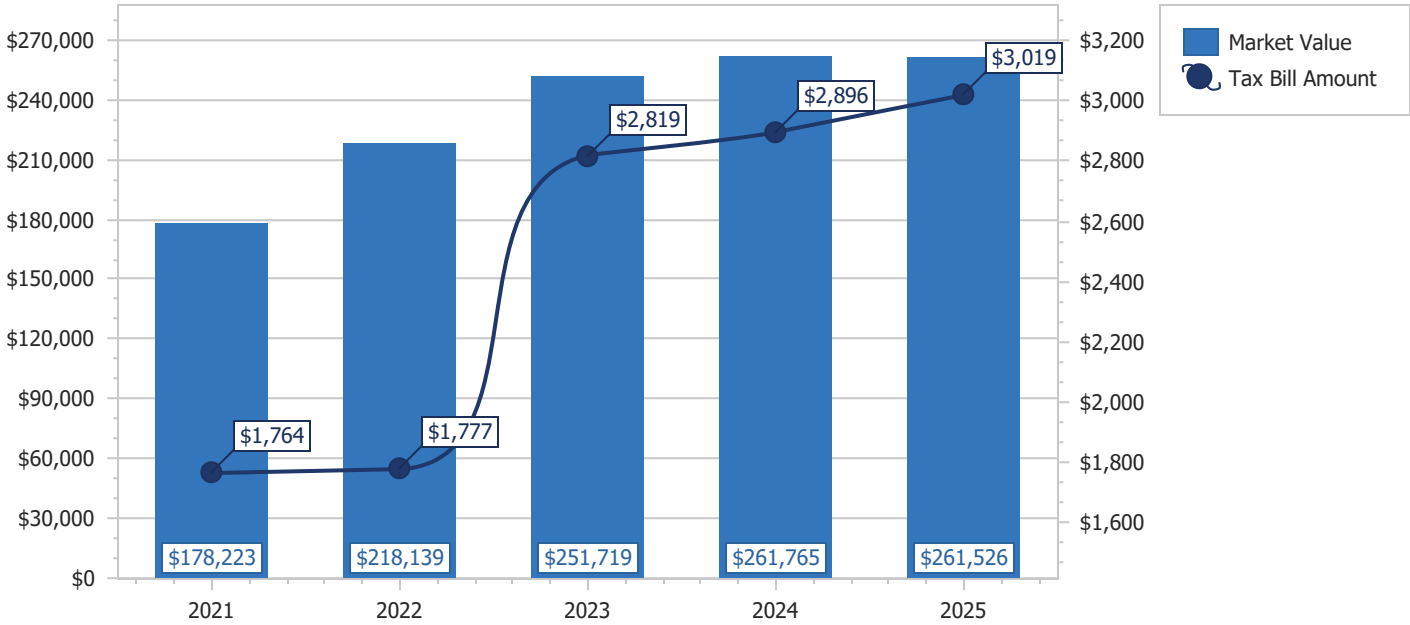

Copyright 2026 © Seminole County Property Appraiser